



Service Instruction

ENGINE COMPONENTS, INC.

S.I. No.: **05-4**

Page: **1 of 3**

Title: CONTINUING AIRWORTHINESS OF LYCOMING OIL PUMP HOUSINGS

Issued: **04/04/05**

Revision: **0**

Technical Portions are FAA DER Approved.

- 1.0 PURPOSE:** This service instruction provides the continuing airworthiness for ECi oil pump housings installed on Lycoming series engines.
- 2.0 MODELS AFFECTED:** All Lycoming models listed in section 4.0 Installation Eligibility.
- 3.0 TIME OF COMPLIANCE:** Whenever ECi oil pump housings are installed in a certificated Lycoming engine.
- 4.0 INSTALLATION ELIGIBILITY:**

Part Name	Part Number	Approved Replacement for	Installation Eligibility
Housing, Oil Pump	AEL78528	Lycoming 78528 76354 76061 69183 69154 69153 60984	O-320-No Suffix, A1A, A1B, A2A, A2B, A2C, A2D, A3A, A3B, A3C, B1A, B1B, B2A, B2B, B2C, B2D, B2E , B3A, B3B, B3C, C1A, C1B, C2A, C2B, C2C, C3A, C3B, C3C, D1A, D1B, D1C, D1D, D1F, D2A, D2B, D2C, D2F, D2G, D2H, D2J, D3G, E1A, E1B, E1C, E1F, E1J, E2A, E2B, E2C, E2D, E2E , E2F, E2G, E2H, E3D, E3H IO-320-A1A, A2A, B1A, B1C, B1D, B1E, B2A, C1A, C1B, D1A, D1B, D1C, E1A, E1B, E2A, E2B, F1A AIO-320-A1A, A1B, A2A, A2B, B1B, C1B; AEIO-320-D1B, D2B, E1A, E1B, E2A, E2B; O-340-A1A, A1B, A2A, B1A, B2A; O-360-A1A, A1C , A1D, A1F, A1F6, A1G, A1G6, A1H, A1H6, A1J , A1P, A2A, A2D, A2E , A2F, A2G, A2H, A3A, A3D, A4A, A4D, A4G, A4J, A4K, A4M, A4N, A4P, B1A, B1B, B2A, B2B, B2C, C1A, C1C, C1E, C1F, C1G, C2A, C2B, C2C, C2D , C2E, C4F, C4P, D1A, D2A, D2B, F1A6, G1A6, J2A; HO-360-A1A, B1A, B1B , C1A; IO-360-A1A, A1B, A1B6, A1C, A1C6 , A1D, A1D6, A2A, A2B, A2C, A3B6, B1A, B1B, B1C, B1D, B1E, B1F, B1F6, B1G6, B2E, B2F, B2F6, B4A, C1A, C1B, C1C, C1C6, C1D6, C1E6, C1F, D1A, E1A, F1A, K2A, L2A VO-360-A1A, A1B, B1A AIO-360-A1A, A1B, A2A, A2B, B1B HIO-360-A1A, A1B, B1A, B1B , C1A, C1B, D1A IVO-360-A1A TIO-360-A1A, A1B AEIO-360-A1A, A1B, A1B6, A1C, A1D, A1D6, A1E, A1E6, A2A, A2B, A2C, B1B, B1E, B1F, B1F6, B1G6, B1H , B2F, B2F6, B4A, H1A, H1B O-540-A1A, A1A5, A1B5, A1C5, A1D, A1D5, A2B, A3D5, A4A5, A4B5, A4C5, A4D5, B1A5, B1B5, B1D5, B2A5, B2B5, B2C5, B4A5, B4B5, D1A5, E4A5, E4B5, E4C5, F1A5, F1B5, G1A5, G2A5, H1A5, H2A5, J3A5



Part Name	Part Number	Approved Replacement for	Installation Eligibility
			IO-540-A1A5, B1A5, B1B5, B1C5, C1B5, C1C5, C2C, C4B5, C4C5, C4D5, D4A5, D4B5, D4C5, E1A5, E1B5, E1C5, G1A5, G1B5, G1C5, G1D5, G1E5, G1F5, J4A5, K1A5, K1B5, K1C5, K1D5, K1E5, K1F5, K1G5, K1H5, K1J5, K1K5, K2A5, L1A5, L1C5, M1A5, M1B5 , M1C5, N1A5, R1A5, T4B5, V4A5, AB1A5 H1O-540-A1A AEIO-540-D4A5, D4B5, D4C5, D4D5, L1B5
Housing, Oil Pump	AEL78531	Lycoming 78531	O-235-C1, C1B, C1C, C2A, C2B, C2C, E1, E1B, E2A, E2B, F1, F1B, F2A, F2B, G1, G1A , G1B, G2A, G2B, H2C, J2A, J2B, K2A, K2B, K2C, L2A, L2C, M1, M2 , M2C, M3C, N2A, N2C, P1, P2A, P2C, P3C O-290- I1 , D, D2, D2A, D2B, D2C O-320-No Suffix, A1A, A1B, A2A, A2B, A2C, A2D, A3A, A3B, A3C, B1A, B1B, B2A, B2B, B2C, B2D, B2E , B3A, B3B, B3C, C1A, C1B, C2A, C2B, C2C, C3A, C3B, C3C, D1A, D1B, D1C, D1D, D1F, D2A, D2B, D2C, D2F, D2G, D2H, D2J, D3G, E1A, E1B, E1C, E1F, E1J, E2A, E2B, E2C, E2D, E2E , E2F, E2G, E2H, E3D, E3H IO-320-A1A, A2A, B1A, B1C, B1D, B1E, B2A, D1A, D1B, D1C, E1A, E1B, E2A, E2B, F1A AIO-320-A1A, A1B, A2A, A2B, B1B, C1B AEIO-320-D1B, D2B, E1A, E1B, E2A, E2B O-340-A1A, A1B, A2A, B1A, B2A O-360-A1A, A1D, A1F, A1F6, A1G, A1G6, A1H, A1H6, A1J , A1P, A2A, A2D, A2F, A2G, A2H, A3A, A3D, A4A, A4D, A4G, A4J, A4K, A4M, A4N, A4P, B1A, B1B, B2A, B2B, B2C, C1A, C1C, C1E, C1F, C1G, C2A, C2B, C2C, C2E, C4F, C4P, D1A, D2A, D2B, F1A6, G1A6, J2A HO-360-A1A, C1A IO-360-A1A, A1B, A1B6, A1C, A1C6 , A1D, A1D6, A2A, A2B, A2C, A3B6, B1A, B1B, B1C, B1D, B1E, B1F, B1F6, B1G6, B2E, B2F, B2F6, B4A, C1A, C1B, C1C, C1C6, C1D6, C1E6, C1F, D1A, E1A, F1A, K2A, L2A, M1A , M1B VO-360-A1A, A1B, B1A AIO-360-A1A, A1B, A2A, A2B, B1B HIO-360-A1A, A1B, B1A, C1A, C1B, D1A, G1A IVO-360-A1A AEIO-360-A1A, A1B, A1B6, A1C, A1D, A1D6 , A1E, A1E6, A2A, A2B, A2C, A2E , B1B, B1D , B1E, B1F, B1F6, B1G6, B1H , B2F, B2F6, B4A, H1A, H1B O-540-A1A, A1A5, A1B5, A1C5, A1D, A1D5, A2B, A3D5, A4A5, A4B5, A4C5, A4D5, B1A5, B1B5, B1D5, B2A5, B2B5, B2C5, B4A5, B4B5, D1A5, E1A , E4A5, E4B5, E4C5, F1A5, F1B5, G1A5, G2A5, H1A5, H2A5, J3A5 IO-540-A1A5, B1A5, B1B5, B1C5, C1B5, C4B5, C4D5, D4A5, D4B5, D4C5, E1A5, G1A5, G1E5, G1F5, K1G5, K1H5, K1J5, K1K5, L1C5, N1A5, T4B5, V4A5, W1A5 , AB1A5, AE1A5 AEIO-540-D4A5, D4B5, D4C5



Part Name	Part Number	Approved Replacement for	Installation Eligibility
Housing, Oil Pump	AEL75287	Lycoming 75287 73877	IO-540-E1A5, E1B5, E1C5, K1B5, K1E5, K1H5, P1A5, S1A5, AA1A5, AA1B5, ACIA5 TIO-540-A1A, A1B, A1C, A2A, A2B, A2C, C1A, E1A, G1A, H1A, J2B, U2A, W2A, AE2A, AF1A, AF1B, AG1A, AH1A, AJ1A, AKIA AEIO-540-LID5 IO-720-A1A, A1B, B1A , B1B, B1BD, C1B, D1B

5.0 APPROVED CONVERSIONS OF OIL PUMP HOUSINGS:

The AEL78528 oil pump housing, which is eligible for most 4-cylinder applications, except 235 and 290 series engines, may be converted to an equivalent oil pump housing to AEL78531 by threading and plugging the oil passage that would normally supply oil to the AN-style fuel pump gear train. The conversion, once accomplished, effectively changes the eligibility of AEL78528 to that of AEL78531 and changes the oil pump housing designation to AEL78531-1. Furthermore, this allows the user to convert from the AEL78531-1 to the AEL78528 housing by removing the set screw plug.

ECi has developed a procedure to convert the AEL78528 housing to the AEL78531-1, which is equivalent to AEL78531. This procedure has been FAA-DER approved and is detailed below. Figure 1 below shows this assembly.

1. Drill and tap Ø.188 hole to 1/4-20UNC-3B thread to depth 0.750 ± 0.010 inch.
2. Install set screw (AE65440-1 or other approved equivalent) using Loctite 271 (or equivalent) to 0.010 inch minimum below surface. Torque to 76–96 in-lbs.
3. Pressure test assembly with 100 psi air to ensure oil-tight seal.

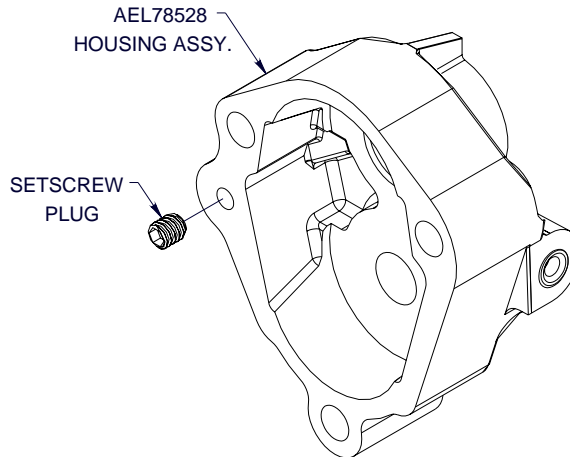

Figure 1: AEL78531-1 Assembly

For more information about this approved conversion, contact ECi at 800-eci2fly or sales-service@eci2fly.com.