



Service Instruction

ENGINE COMPONENTS, INC.

S.I. No.: 95-9-1

Page: 1 of 1

Title: CORNER STUD HOLES IN TCM CYLINDER BARREL FLANGES

Issued: 11/28/95

Revision: 2 (12/21/01)

Technical Portions are FAA DER Approved.

Models Affected: All TCM 4 7/16, 5 AND 5 1/4 inch bore diameter cylinders except military models.

Engine Components, Inc. (ECi) has FAA Engineering Approval to drill 7/16 inch diameter flange corner stud holes to 1/2 inch diameter, and 3/8 inch diameter corner stud holes to 7/16 inch diameter for the TCM 360 series cylinders. This alteration facilitates the barrel installation after cylinder head heat treatment or the incorporation of the Cerminil™ process.

Testing has shown this alteration does not affect the installation of the cylinder on the crankcase or change the stud preload (stretch), strength or operating characteristics of the cylinder on the engine.

This alteration is reflected on Engine Components, Inc. drawing AEC631397 (new barrels), drawing AEC65381R (used barrels) and is documented and approved through EC Report 9408-2.

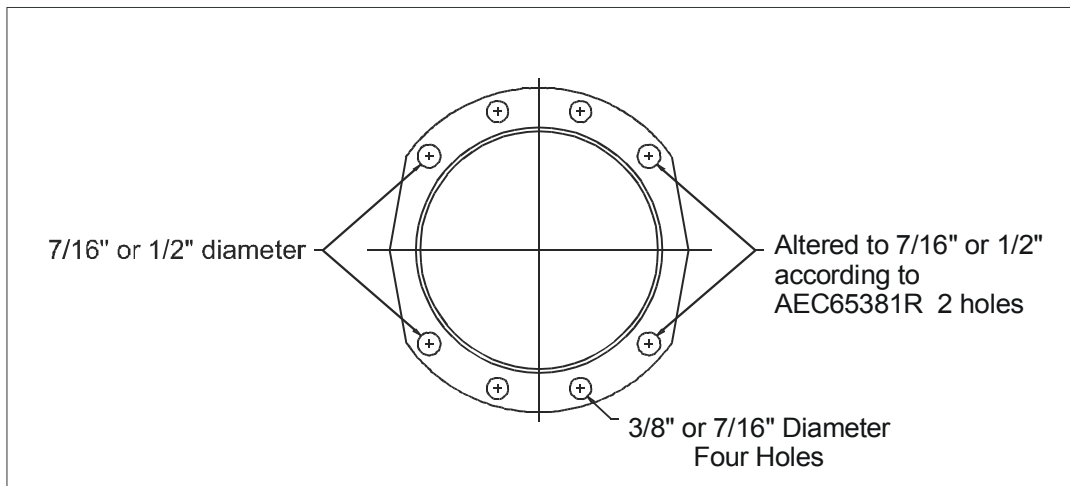

ECi - TEXAS

ECi - OREGON

Corporate Office • 9503 Middlex • San Antonio, TX 78217 • Tel (210) 820-8100 • Fax (210) 820-8103 • 800-ECi-2FLY (800-324-2359)
www.eci2fly.com • sales-service@eci2fly.com • FAA Repair Station #AG2R689K

Airmotive Steel, Classic Cast, Cerminil, Cermicrome, Cerminil, Double Band, Engine Redi, Electro-Fusion, EC Focus, Freedom, IFR, Nerodize, Q3, Q4 & Q5 are Trademarks of ENGINE COMPONENTS, INC.